

# “V” Series – Stationary Inflatable Truck Shelter

## INSTALLATION INSTRUCTIONS

### Wood Frame Shelter

READ ALL INSTRUCTIONS BEFORE INSTALLING SHELTER. SUPER SEAL MFG. LTD. WILL NOT BE HELD RESPONSIBLE FOR IMPROPER INSTALLATION OF ANCHORING DEVICES, OR FOR INSTALLATION INTO AGED OR UNSOUND CONCRETE, CONCRETE BLOCK, OR OTHER WALL OR FLOOR MATERIAL WHICH MAY RESULT IN PREMATURE PRODUCT WEAR, PRODUCT FAILURE, PROPERTY DAMAGE, OR PERSONAL INJURY.

Models: V14, V18 & V22

Model: V1024

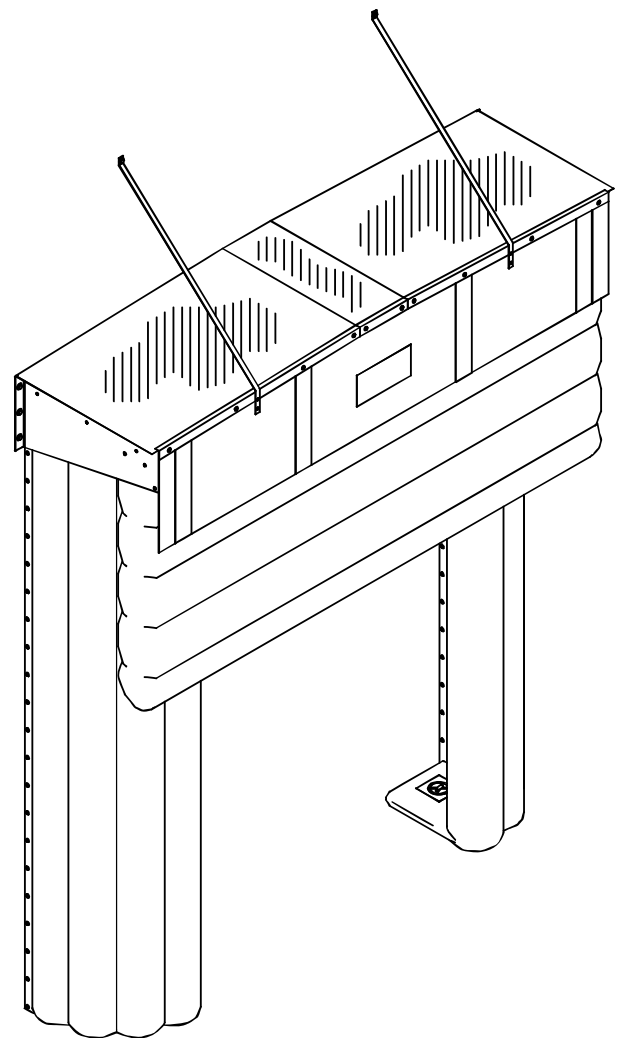
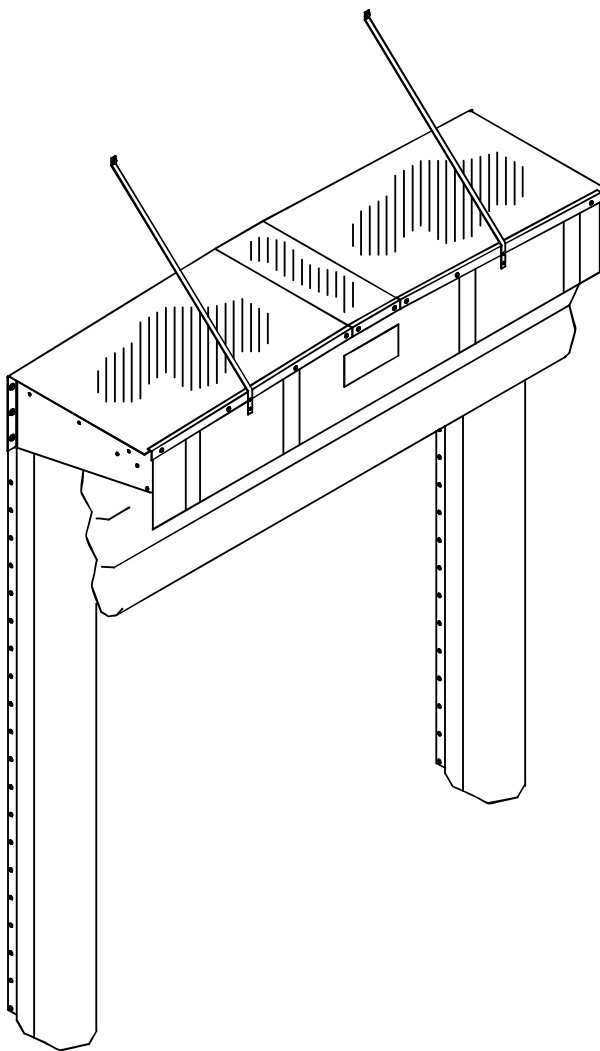

The Following Lists Cover Basic Installation, Not Including Options.

**Components List (Per Assembly)**

No.	Description	Qty.
1	Head Canopy C/W ANGLE TRIM	1
2	Head Air Bag (Mounted To Head Canopy)	1
3	Vertical Wood Backing	2
4	Vertical Air Bags	2
5	½ HP Motor/Blower	1
6	Head Storage Curtain	1
7	Canopy Support Straps	2

**Hardware List (Per Assembly)**

No.	Description	Qty.
1	3/8" X1 7/8" Sleeve Anchor-Zinc	8
2	3/8" X 3" Sleeve Anchor-Zinc	9
3	No. 14 x 1-1/2" Flat Quad Screws	60
4	3/8" Washers	62
5	5/16" x 3" Lag Screws	2
6	1-1/2" Roofing Nails	10
7	Hose Clamps	4
8	Flexible Ducting	2
9	On/Off Switch	1
10	Blower Strap	1
11	Installation Instructions	1
12	# 10-3/4" Tek Screws C/W Washers	10
13	3.5 mm Bungee	4

**Recommended Tools  
(Typical Masonry Wall)**

No.	Description	Qty.
1	Tape Measure	1
2	Plumb Line or Level	1
3	Pencil or Marker	1
4	Square	1
5	Power Drill	1
6	Caulking Gun	1
7	Caulking-Outdoor Acrylic Tape	1
8	Hammer Drill	1
9	Hammer	1
10	3/8" Masonry Drill Bit	8
11	7/16" Socket Driver Bit	1
12	#3 Roberts or #3 Philips drive bit	1
13	½" Socket Wrench	1
14	5/16" Hex Nut Driver	1
15	Utility Knife	1

## 1. CHECK ORDER

### a. Measure Door Opening Height and Width.

- Door seal opening varies according to existing door dimensions.
- Make sure dimensions match Purchase Order.
- Make sure there is enough space to install shelter
- For models V-14, V-18 & V-22 (See Fig. 1a)
- For model V-1024 (See Fig. 1b).

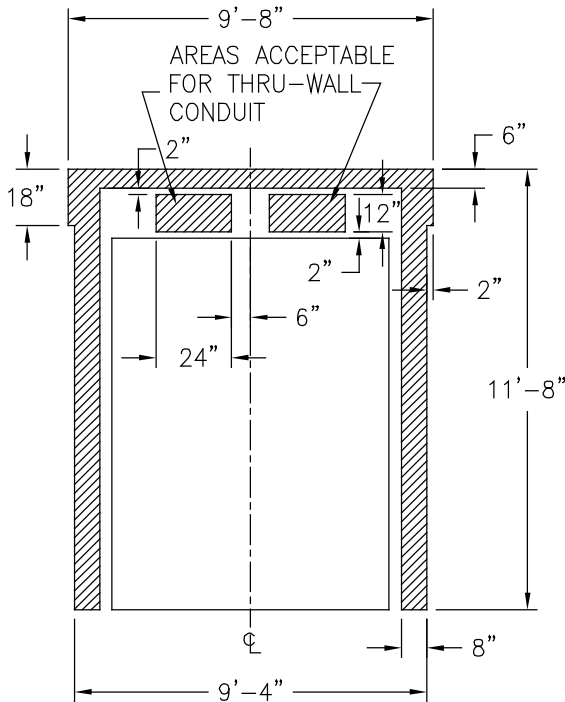

V14,18 & 22  
FIG. 1a

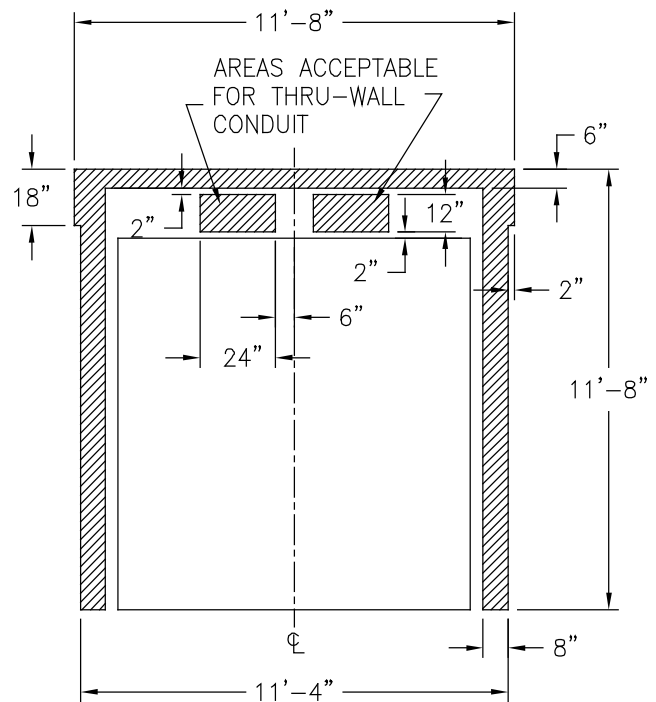

V-1024  
FIG. 1b

### \*Check for existing:

- Dock seals
- Bollard and obstacles
- Lights and conduit
- Drains
- Check *Components List* and *Hardware Supplied List* for all required items (Page 2).
- Check *Recommended Tools List* and make sure all items are available (Page 2).

### Recommended Methods for:

#### a. Concrete Block, Pre-cast Concrete, or Brick Wall:

- Use supplied sleeve anchors.
- If anchors will not hold, 3/8" threaded rods are recommended (supplied by others).

#### b. Metal Siding:

- Use 3/8" threaded rod for through-bolt fastening with steel or wood backup plate (not supplied).

## 2. Mark Centerline Of Door Opening.

### a. Measure and Mark Center of Dock Door Opening (Fig. 2).

- Mark centerline on dock floor.
- Mark centerline on lintel above door.
- Extend line to 11'-8" above dock floor.
- Make sure marks are plumb to each other.

### b. Draw a level line even with the dock floor along both sides of dock face (Fig. 2).

### c. Measure Head Frame width (DO NOT INCLUDE MOUNTING FLANGE) and divide by 2.

### d. Mark Vertical Board positions.

- Measure 1/2 the Head Frame width from dock floor centerline to one side of level line.
- Mark
- Repeat for other side

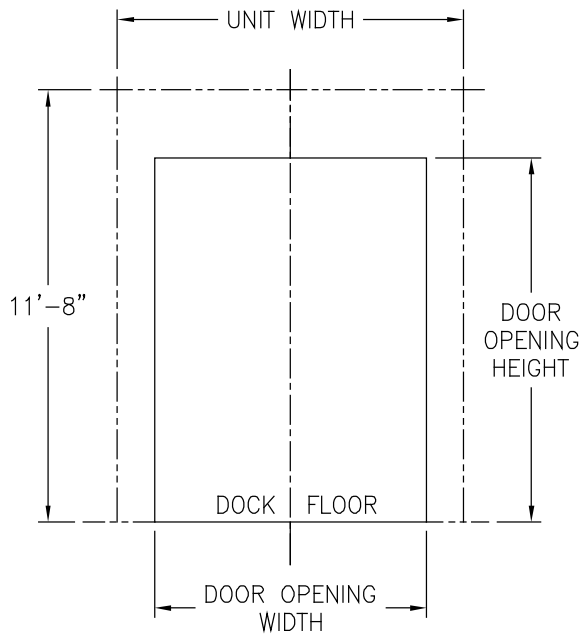

FIG. 2

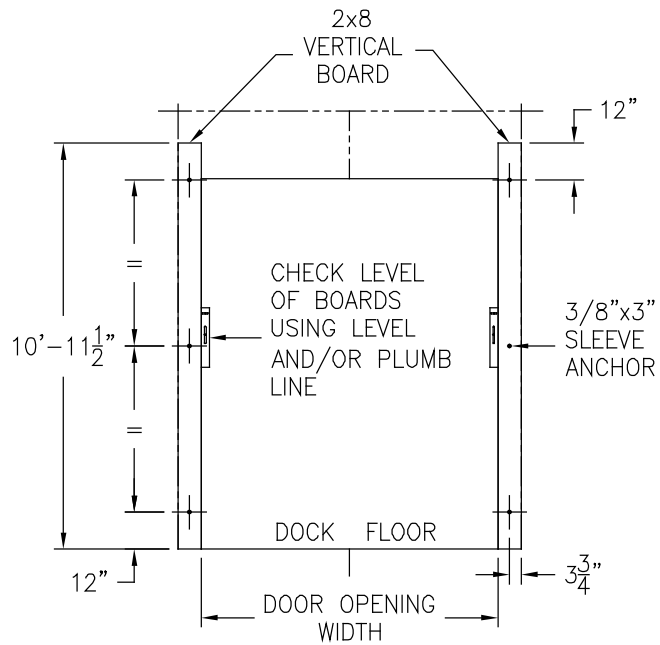

FIG. 3

## 3. ATTACH VERTICAL BOARDS TO WALL.

### a. Position Vertical Board.

### b. Make sure Vertical Board is plumb, level, and square.

### c. Attach Vertical Board to wall (Fig 3).

- Measure and drill 3/8" holes 12" from each end of the vertical board and at the center.
- Insert 3/8" x 3" sleeve anchors into holes.
- Secure using 1/2" socket driver bit.
- Repeat for other Vertical Board.

#### 4. ATTACH VERTICAL AIR BAGS TO VERTICAL BOARDS.

##### a. Fasten and mount.

- Align the air bag with the vertical board at the bottom corners.
- Fasten each corner using no. 14 x 1 1/2" flat quad screws. Tighten with #3 Philips or #3 Roberts driver bit (Fig. 4).
- Screw into each grommet hole using the screws provided across the bottom and up each side and top.
- Repeat for other side.

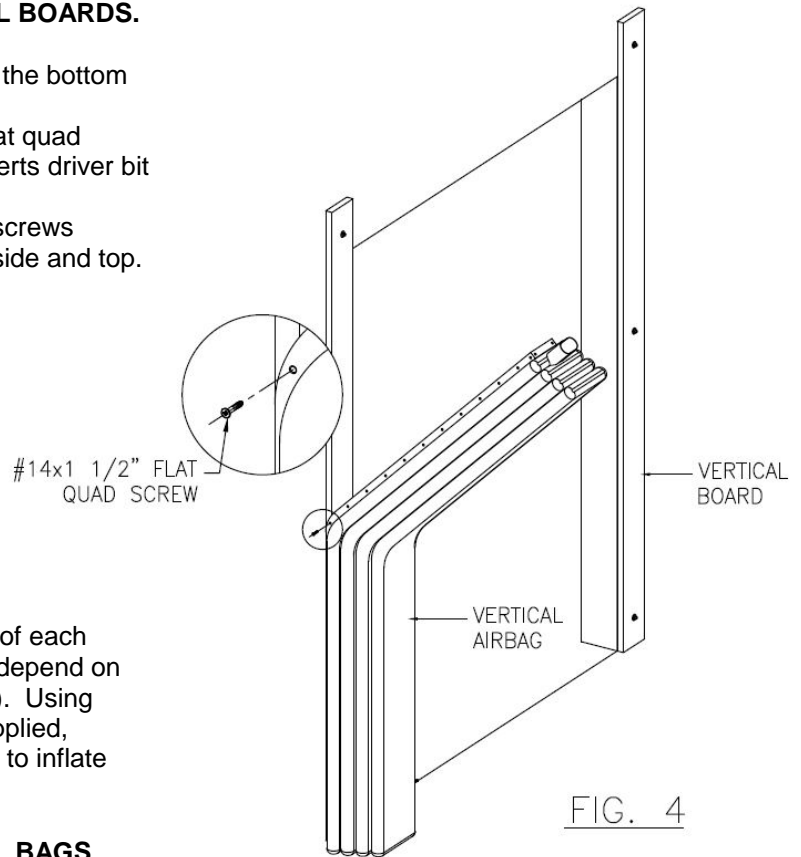

FIG. 4

**b. Mount retraction cords:** At the bottom corner of each Vertical there are "D" rings. Quantity of 'D' Rings depend on the size of the unit (use Figures as reference only). Using the bungees and 3/8" x 1-7/8" Sleeve Anchors supplied, mount bungees to wall at an angle that allows unit to inflate to its full travel and deflate properly.

**Note: RUN BUNGEEES UNDER THE VERTICAL BAGS SO THAT THE BUNGEE CORD DOES NOT PRESS ON THE FACE OF THE INFLATABLE (Figure 4A).**

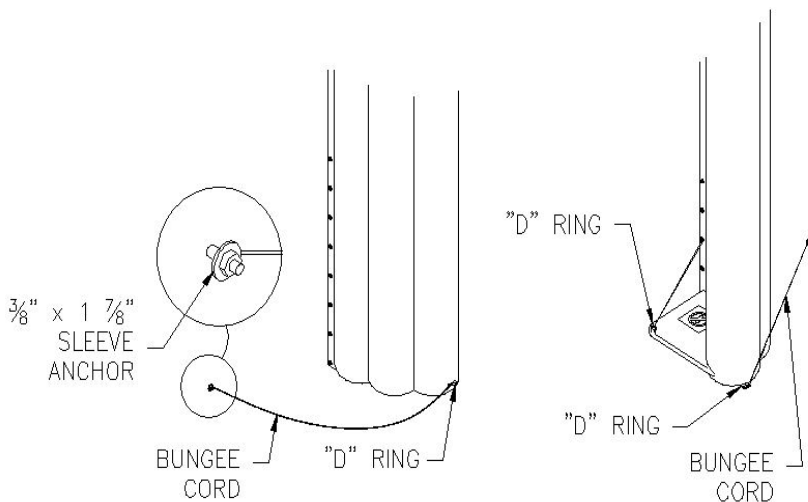

FIG. 4A

## 5. MOUNTING HEAD FRAME

### a. Prepare frame (Fig. 5).

- o Determine front and back on head frame.

**NOTE: THE FRONT HAS AN ANGLE TRIM.**

- o Remove angle from front edge, using #3 Roberts or #3 Philips drive bit.

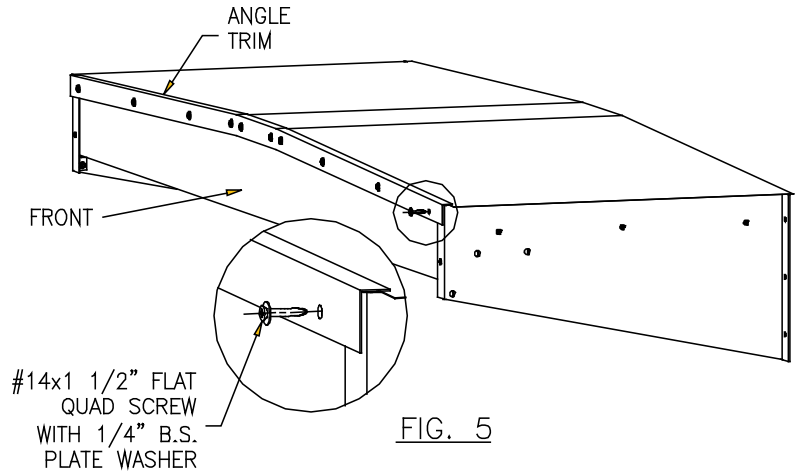

FIG. 5

### b. Remove head air bag assembly from head frame.

- o Place head frame upside down on clean flat 2 x 4 supports (Fig. 6a).

**NOTE: DO NOT PUNCTURE OR SCRATCH METAL SIDING.**

### c. Remove 5/16" x 3" lag bolts from front of head frame using 1/2" socket wrench (Fig. 6b).

### d. Slide head air bag assembly off the header bag brackets (Fig. 6c).

- o Slide towards back of head frame.
- o Do not drop head air bag assembly.
- o Place head air bag assembly on clean, flat surface.

### e. Lift head frame above verticals.

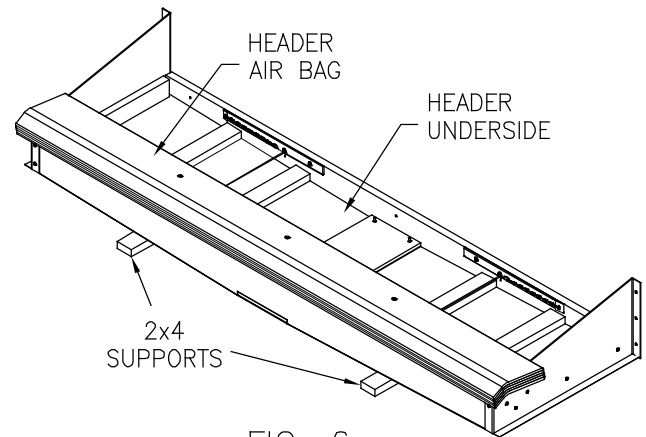

FIG. 6a

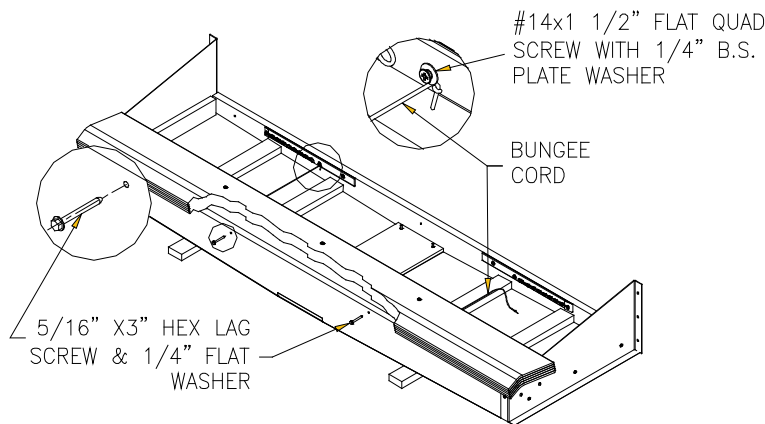

FIG. 6b

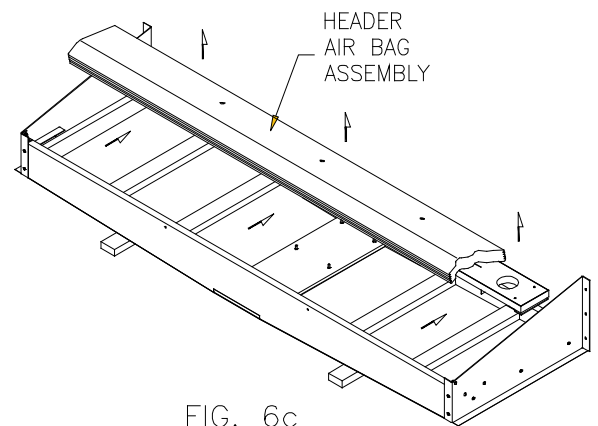
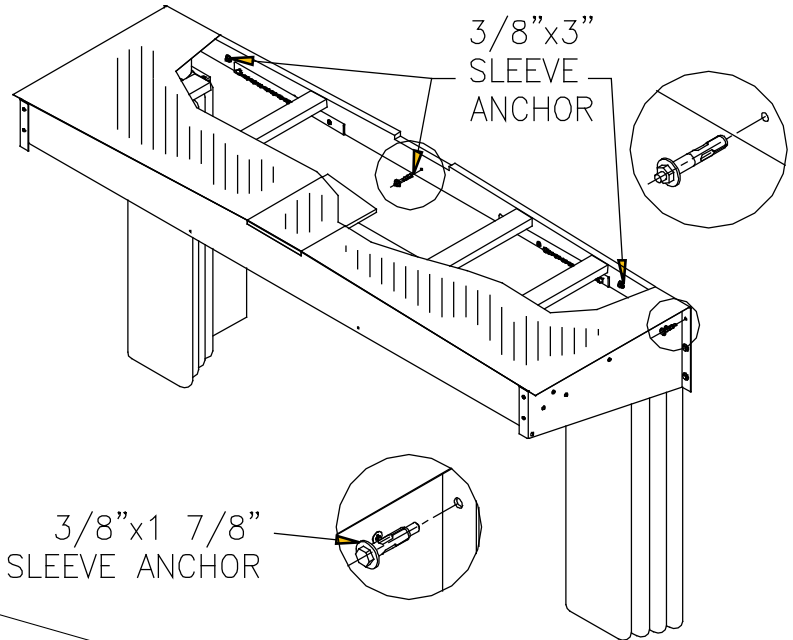

FIG. 6c

**NOTE: USE SAFE, APPROPRIATE LIFTING METHOD.**

- Place head frame on outside of left and right vertical air bags (Fig. 7a).
- Position head frame flush to wall (Fig. 7a).
- Drill hole through head frame backboard using 3/8" drill bit (Fig. 7b).
- Insert 3/8" x 3" sleeve anchor into holes (Fig. 7b).
- Tighten and secure using 1/2" socket driver bit (Fig. 7b).
- Repeat for left and right support brackets.



**NOTE: THIS SHELTER MUST BE PLUMB, LEVEL, AND SQUARE, IN ORDER TO FUNCTION PROPERLY.**

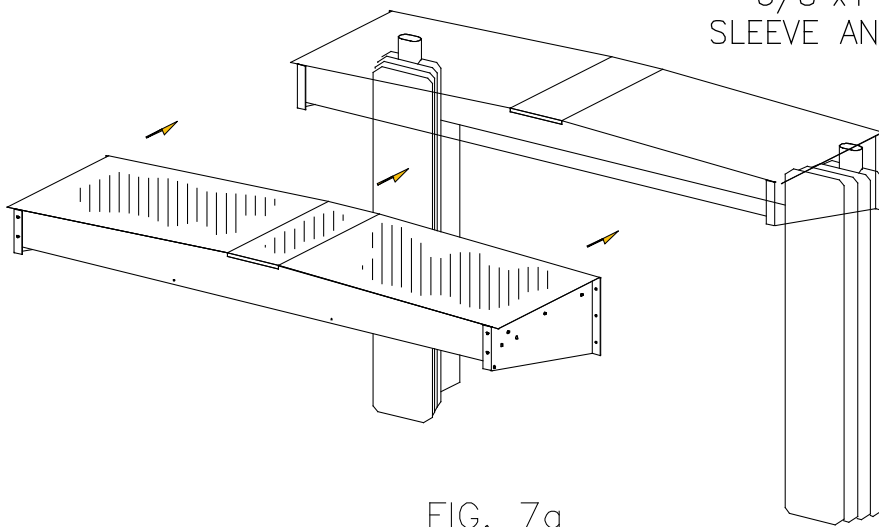

FIG. 7a

3/8" x 1 7/8"  
SLEEVE ANCHOR

FIG. 7b

## 6. Attach Canopy Support Strap.

- Attach lower end of canopy strap to face of header at about 2ft. in from the edge. Use No.14 x 1-1/2" flat quad screws & tighten using #3 Philips or #3 Roberts driver bit (Fig. 7c).
- Pull up on canopy support strap and mark hole location on wall.
- Using a 3/8" masonry drill bit, drill hole for 3/8"x3" sleeve anchor (Fig. 7c).
- Insert 3/8"x 3" sleeve anchor and tighten using 1/2" socket wrench.
- Repeat for other side.

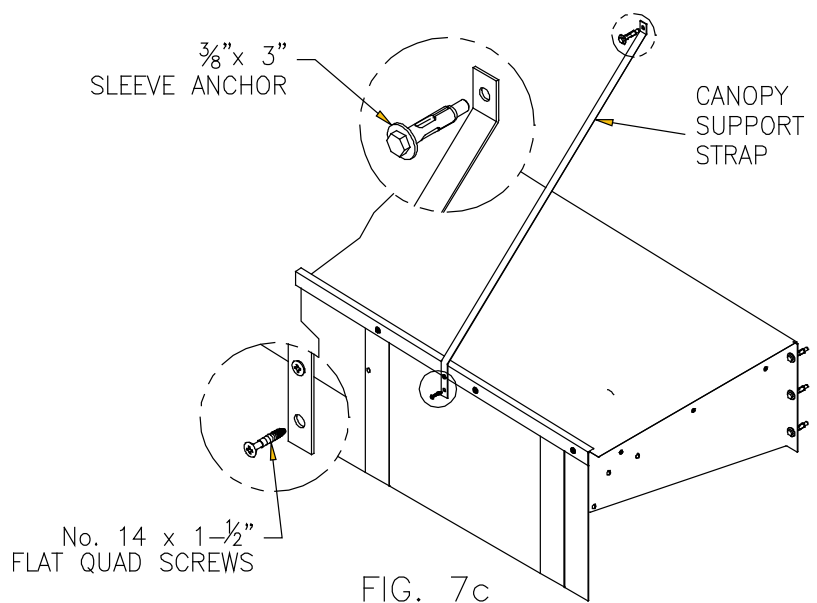

FIG. 7c

## 7. Re-Attach Head Air Bag Assembly.

### a. Insert header air bag assembly in head frame.

Note: Head curtain bracket goes into head frame bracket (Fig. 8).

- Insert 5/16" x 3" lag bolts and tighten, using 1/2" socket wrench (Refer back to Fig. 6b).

### b. Connect air bags.

- Position and slide hose clamps around throats (Fig. 9).

### c. Insert flexible ducting into throats.

- Attach hose clamp around throat.
- Insert flexible ducting into throat (Fig. 10).
- Place deep enough into air bag so that the flexible ducting extends below top of air bag.
- Tighten with 5/16" hex nut driver.
- Repeat for other throat.

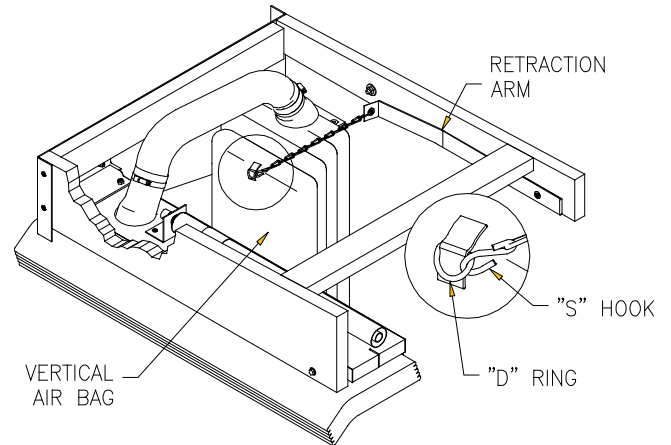
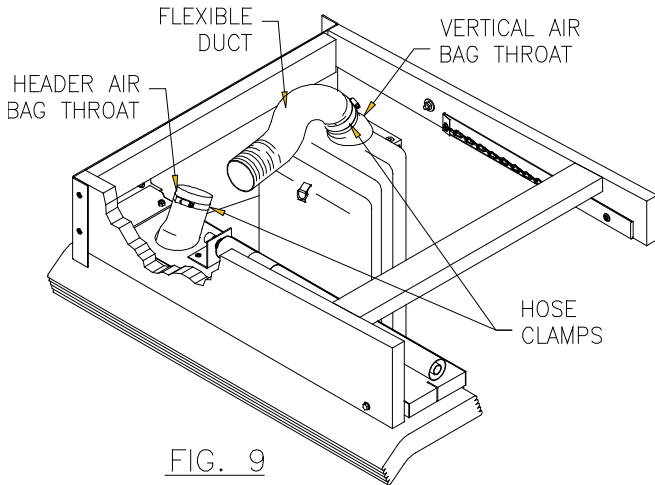
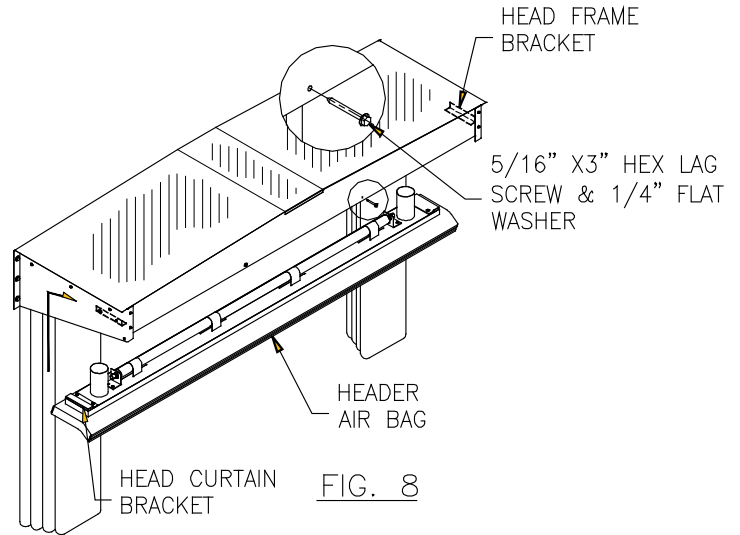

## 8. Attach bungee Cord To Head Bag.

- Unravel bungee cord on header frame back board.
- Attach "S" hook on end of bungee cord to "D" ring of head bag (Fig. 11).
- Close "S" hook with pliers.
- Repeat for other side.

NOTE: STANDARD AIR BAGS ONLY HAVE TWO (2) "D" RINGS PER UNIT, ONE ON EACH SIDE. AIR BAGS WITH DROPS EXCEEDING 48" HAVE FOUR (4) "D" RINGS, TWO (2) PER SIDE. THE LONGEST BUNGEE CORD GOES TO THE BOTTOM "D" RING, AND THE SHORTEST BUNGEE CORD GOES TO THE TOP "D" RING.

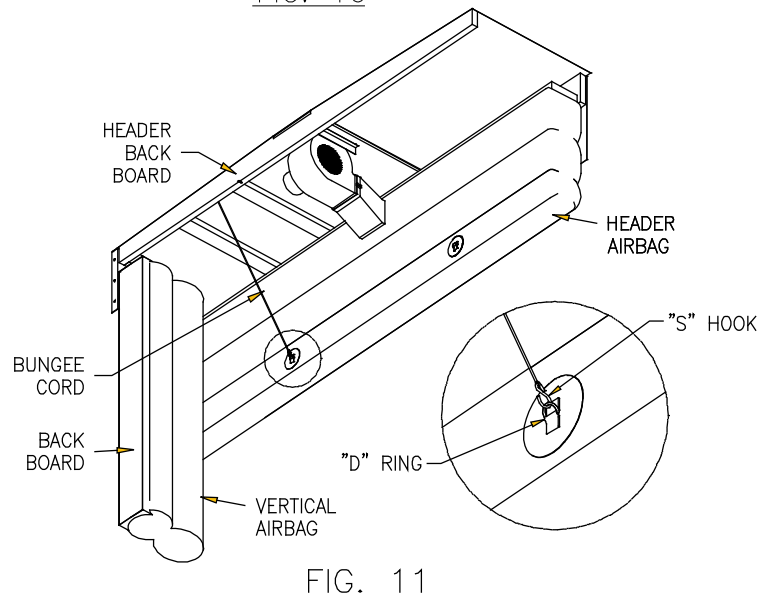



## 9. CONNECT RETRACTION ARM TO VERTICAL AIRBAG.

### Connect Retraction Arm.

- Insert "S" hook at end of chain on retracting arm into "D" ring at leading edge of Vertical Bag (Fig.10).
- Close off "S" hook using pliers.

## 10. MOUNTING MOTOR/BLOWER

### a. Mount motor/blower on head frame.

- Remove ¼" nuts and lock washers from Motor/Blower bolts on head frame, using 7/16" socket wrench.
- Mount motor/blower (Figure 11).
- Air duct should face the front of the shelter.
- Match motor/blower mounting holes with bolts.
- Replace lock washers and nuts on bolts.
- Tighten ¼" nuts using 7/16" socket wrench.

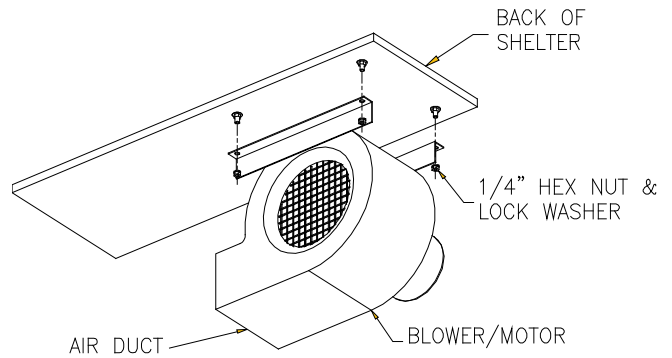

FIG. 11

### b. Connect header air bag to motor/blower.

- Pull header air bag throat material over blower throat (Fig. 12).
- Make sure the material will not interfere with airflow.
- Carefully trim excess material, if needed, using utility knife.
- Secure into place with blower strap.

### c. Reattach retraction bungee cord assembly to head frame.

- Pull bungee cord (looped end) to back of head frame (Fig. 12).
- Insert No.14 x 1 ½" flat quad screws through bungee cord loop into predrilled holes in back of head frame.
- Tighten with #3 Roberts or #3 Philips driver bit.
- Repeat for other side.

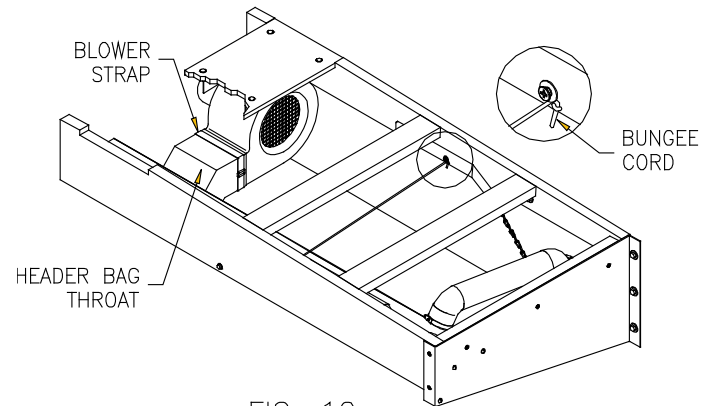
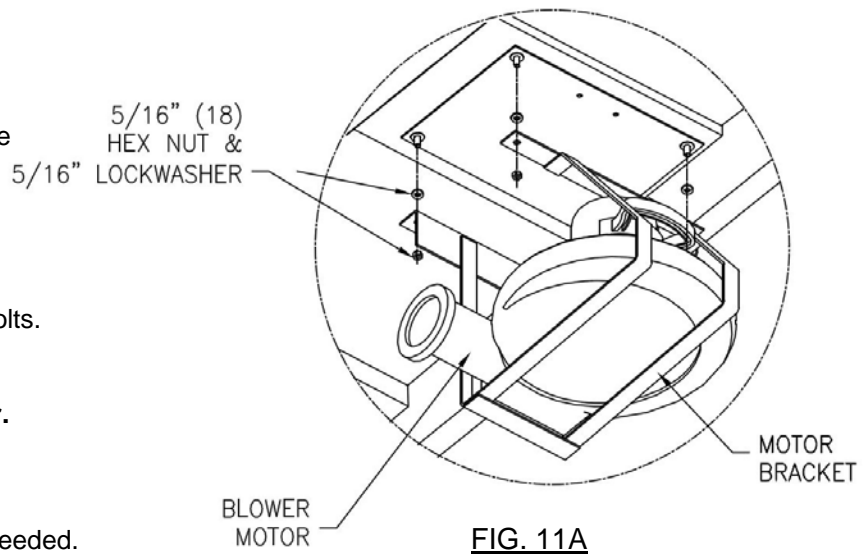

FIG. 12

**OR: Mount Motor/Blower**

**a. Mount Motor/Blower on Head Frame.**

- Remove nuts and lock washers from Motor/Blower bolts on Head Frame.
- **Mount Motor/Blower** (Figure 11A).
  - Air duct should face the front of the shelter
    - Match bracket mounting holes to plate and header.
  - Bolt bracket and plate to header.
  - Slide Blower onto bracket.
- **Replace lock washers and nuts** on bolts.
- **Tighten.**



**FIG. 11A**

**b. Connect Header Air Bag to Motor/Blower.**

- **Pull material over Blower Throat.**
  - Make sure the material will not interfere with airflow.
  - Carefully trim excess material, if needed.
- **Secure into place with Blower Strap.**

**c. Reattach Retraction Bungee Cord Assembly to Head Frame (Figure 12A).**

- Pull Bungee Cord Assembly to back of Head Frame.
- Insert screws through Assembly into pre-drilled holes in back of Head Frame.
- Tighten.
- Repeat for other side.

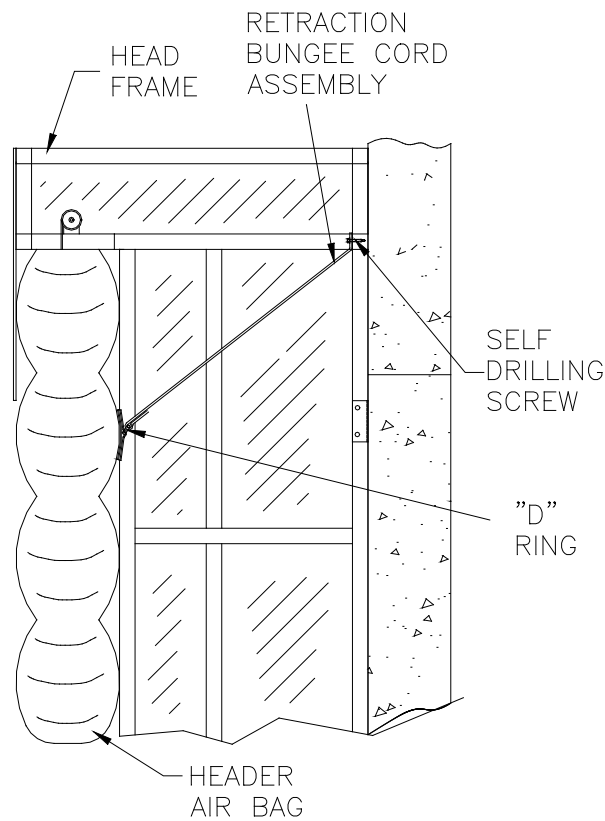

**FIG. 12A**

## 11. ATTACH HEAD STORAGE CURTAIN TO HEAD FRAME.

### a. Position and secure head storage curtain (Fig. 13).

- Logo is on the front of head storage curtain.
- Match top center of head storage curtain with top center of head frame (Figure 13).
- Place raw edge flush to frame edge.
- Secure with roofing nails within 2" of top edge.

**NOTE: AVOID NAILING THROUGH STAYS.**

- Spread rest of head storage curtain along front of head frame.
- Keep flush with edge, ensuring a tight fit.
- Drill No.14 x 1 1/2" flat quad screws with 1/4" B.S. washers into stays at approx. 2 1/2" down from top edge and centered on stays.

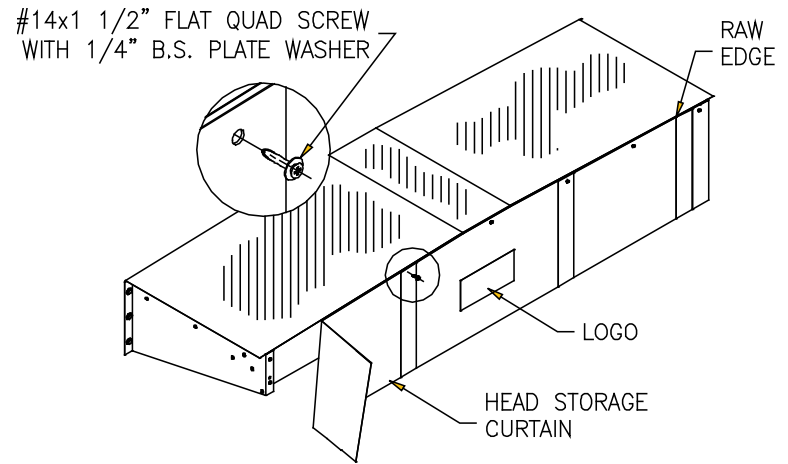

FIG. 13

### b. Reattach angle to front edge of head frame (Fig. 14).

- Screw No.14 x 1 1/2" flat quad screws with 1/4" B.S. plate washers into predrilled holes in angle.
- Tighten with #3 Roberts or #3 Philips driver bit.

## 12. FINISH INSTALLATION

### a. Caulk between head frame and wall.

- An outdoor acrylic type caulking is recommended.

**NOTE: IF MOUNTING ON SIDING OR ON PRE-CAST CONCRETE, FILL IN GAPS WITH STYROFOAM.**

#### Caulk along:

- Outside of head frame along wall.
- Head frame angle.
- Fill in any remaining gaps around unit as needed.

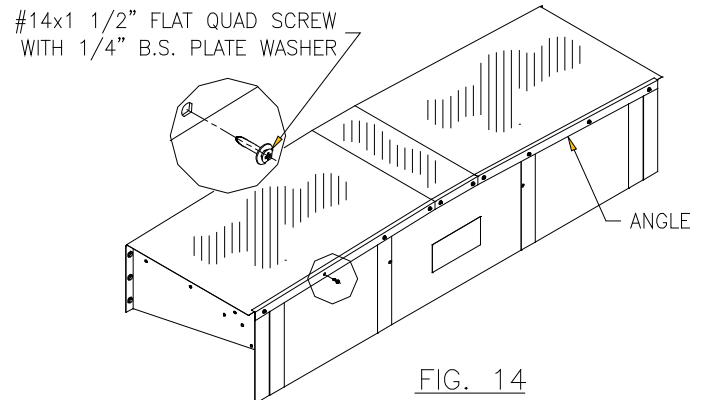

FIG. 14

# ELECTRICAL INSTRUCTIONS & SCHEMATICS

## ELECTRICAL INSTALLATION

**READ ALL INSTRUCTIONS AND PURCHASE ORDER BEFORE INSTALLING ELECTRICAL COMPONENTS. A LICENSED ELECTRICIAN MUST PERFORM ELECTRICAL INSTALLATION AND HOOK UP. ELECTRICAL INSTALLATION MUST BE IN ACCORDANCE WITH ALL FEDERAL, STATE, AND LOCAL ELECTRICAL CODES AND REGULATIONS.**

**ALL HARDWARE AND ELECTRICAL SUPPLIES ARE PROVIDED BY THE CUSTOMER.**

### Make Electrical Connections (Single Phase 115 Volt)

- a. **Mount ON/OFF switch.**
- b. **Or (OPTIONAL) Auto Switch Kit if ordered,** please see Auto Switch Kit instructions.
- c. **Install an outdoor receptacle** above the door opening on the outside.
- d. **Plug in the Motor/Blower.** Ensure Motor/Blower cable is properly tied back to avoid damage or injury.

115 VOLT	MODEL: KP-680
MOTOR POWER	680 WATTS
AMPS	4.5 A
WEIGHT	13 LBS
UNIT SIZE	16.2X14.2X11
ATTACHED CORD	6 FT, 3 PRONG

### NOTE: THE MOTOR/BLOWER HAS A WIRE LEAD C/W 3 PRONG PLUG.

- **For units Outside North America** (1/2HP, 2850 rpm) motor requires wiring to motor junction box.
- **For 3-Phase power units** (208, 480, 575) motor requires wiring to motor junction box.

### NOTE: THE MOTOR/BLOWER HAS A STICKER SHOWING THE WIRING DIAGRAM.

### Test Shelter

- a. **Make sure Air Bag travel is free** of objects or debris.
- b. **Flip ON/OFF switch to ON.**
  - Motor/Blower should come on immediately.
- c. **Observe inflation.**
  - Let unit fully inflate.
  - Make sure all air bags fully extend to dimension noted on Purchase Order.
- d. **Flip ON/OFF switch to OFF.**
  - Motor/Blower should turn off immediately.
- e. **Observe deflation.**
  - Vertical Air Bags should deflate and retract behind the Vertical Storage Curtains.
  - Header Air Bag should deflate and retract into the Header.
  -

### NOTE: DO NOT INFLATE UNIT WITHOUT A TRAILER IN DOOR OPENING UNLESS TESTING OR MAINTAINING SHELTER.